

MODEL RAH-MB7-SC METAL BUILDING ROOF ACCESS HATCH & CURB

SPECIFICATIONS:

INSIDE OPENING 2'6" x 3'0"

HEAVY DUTY INTERIOR/EXTERIOR
OPENING DEVICE WITH PADLOCK
PROVISIONS

SPRING OPERATOR ASSEMBLIES

INSULATED LID WITH 22 GA LINER

HOLD OPEN ARM

HEAVY DUTY HINGE ON 30" DOWNSLOPE
SIDE WITH 3/8" PIVOT PINS

INSULATED 14 GAUGE NON-PITCHED
ALUMINIZED STEEL MB CURB

12" UPSLOPE CURB HEIGHT

ALL WELDED CURB CONSTRUCTION
CORNERS WELDED

UPSLOPE FLANGE WITH "UNDER"
CONTOURS AND A WATER DIVERTER

DOWNSLOPE WITH "OVER" CONTOURS

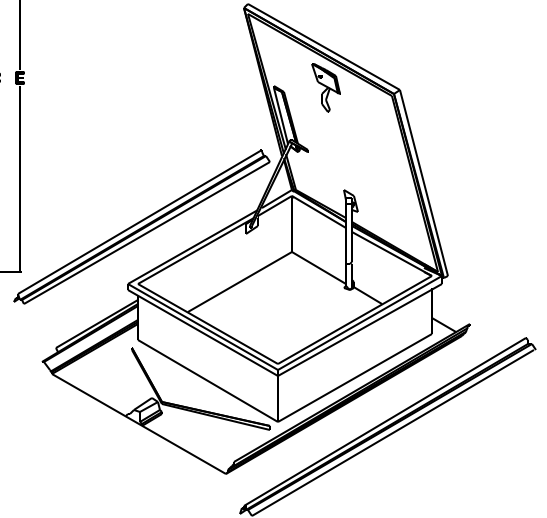
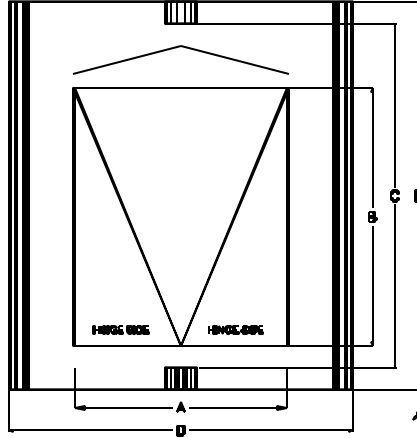

OPTIONS:

SPECIAL HINGE LOCATION

DOMED LID

AIR DRY ENAMEL FINISH
(CURB ONLY) -

WHITE
 CUSTOM COLOR

SPECIAL SIZES

SPECIAL RIB PLACEMENT

WIDE FLANGES

UPSLOPE
 DOWNSLOPE

CRICKET IN LIEU OF DIVERTER

SUB FRAMING

2-1/2" WIDE MASTIC

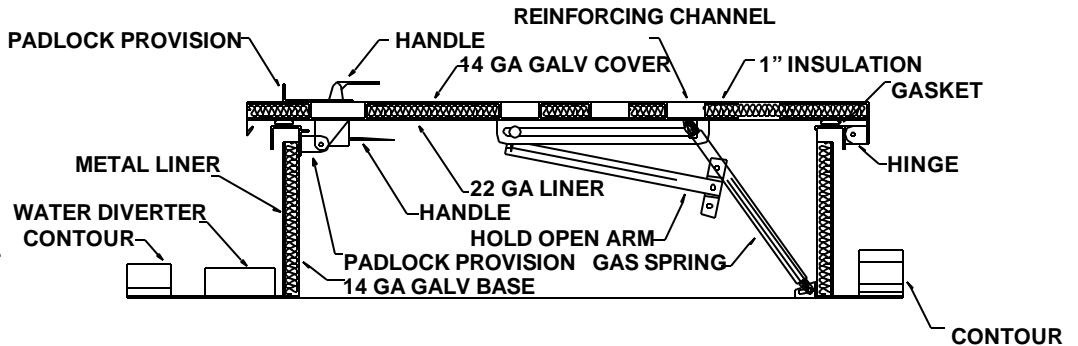

MODEL	INSIDE CURB DIM A	CURB DIM B	DIM C	DIM D	DIM E	QTY
RAH2630MB7-SC	30"	36"	48"	48"	54"	

ROOF PANEL MANUFACTURER	PANEL MODEL

PROJECT _____
LOCATION _____
DATE _____

CONTRACTOR _____
APPROVED BY _____
DATE APPROVED _____

R & S SALES COMPANY, INC.
3575 Old Conejo Road, NEWBURY PARK, CA 91320
PHONE 805-375-3980 FAX 805-375-3981

MODEL RAH-MB7-SC & RAH-MB8-SC INSTALLATION DETAILS

1. On a fully sheeted roof, mark centerline of roof opening.

2. Use centerline of roof panel as a guide and lay out roof opening to match the curb "C" & "D" dimensions.

3. Cut roof opening per building manufacturer's recommendations.

4. Install structural support framing for curb and equipment loads. Keep inside dimension clear. A minimum of two parallel curb walls should be supported. Avoid cantilever sections in excess of 12".

5. Apply mastic or sealant tape at points where curb meets roof panel. Apply to roof panel at downslope flanges. Apply to curb upslope flange. Use only accessories as recommended by the building manufacturer.

6. Press curb into place on the roof panel. Upslope flange goes under roof panel; downslope over roof panel.

7. Fasten the curb to support structure through curb up and downslope flanges and roof panel using fasteners compatible with the roof system. Use a minimum of four fasteners per side on maximum 4" centers.

8. Crimp roof panel seams over or against vertical ends of curb side panels to provide clearance for seam clips. Apply mastic and sealants to sides where seam clips are placed. Fasten seam clips with a minimum of four fasteners per side on maximum 4" centers.

9. Check tightness of fasteners and general integrity of installation. Caulk perimeter edge of curb flanges to roof panel.

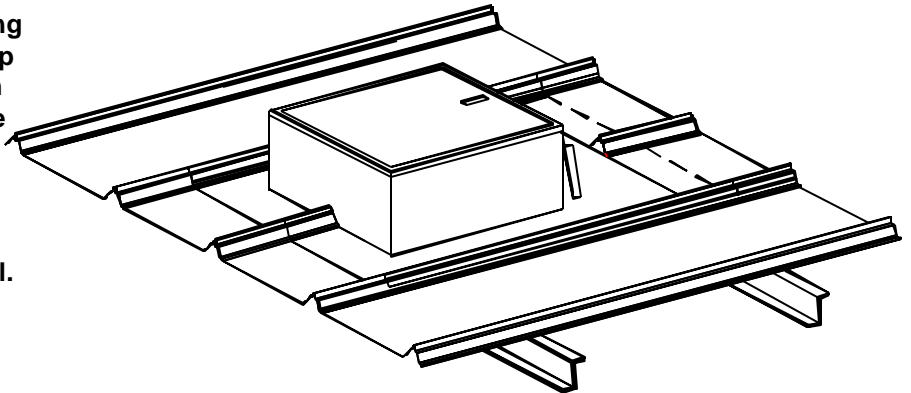
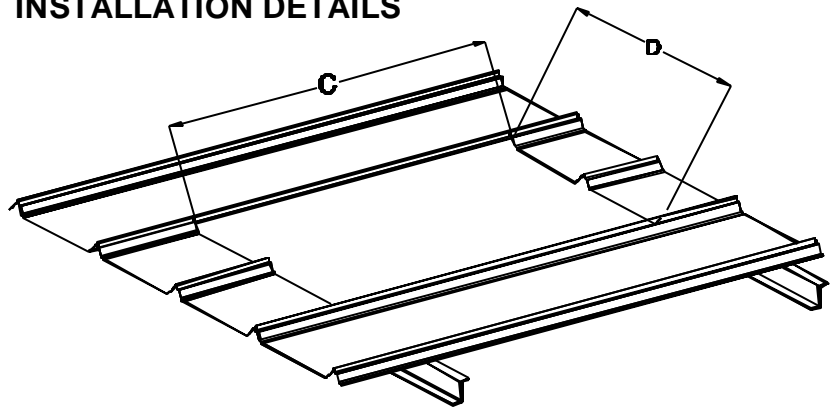

SIDE SECTION

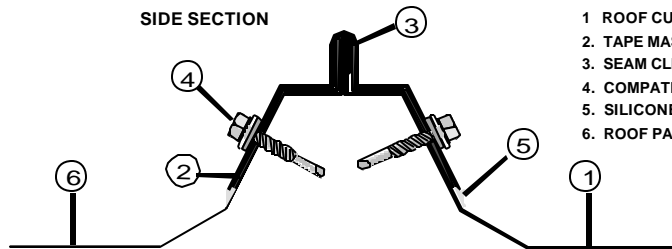

- 1 ROOF CURB WALL
- 2 TAPE MASTIC
- 3 SEAM CLIP
- 4 COMPATIBLE FASTENER
- 5 SILICONE/URETHANE SEALANT
- 6 ROOF PANEL

DOWNSLOPE SECTION

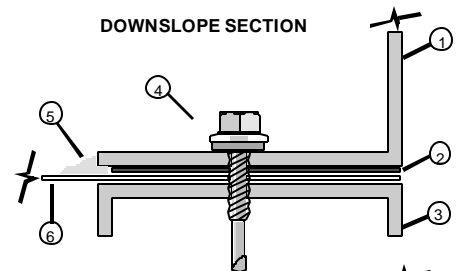

- 1 ROOF CURB WALL
- 2 TAPE MASTIC
- 3 SUPPORT FRAMING
- 4 COMPATIBLE FASTENER
- 5 SILICONE/URETHANE SEALANT
- 6 ROOF PANEL

UPSLOPE SECTION

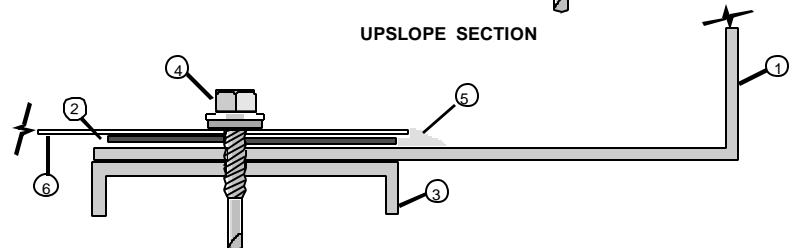

R & S SALES COMPANY, INC.

3575 Old Conejo Road, NEWBURY PARK, CA 91320
PHONE 805-375-3980 FAX 805-375-3981