

MODEL RAH-MB7 METAL BUILDING ROOF ACCESS HATCH & CURB

SPECIFICATIONS:

- INSIDE OPENING 2'6" x 3'0"
- HEAVY DUTY INTERIOR/EXTERIOR OPENING DEVICE WITH PADLOCK PROVISIONS
- GAS SPRING OPERATOR
- INSULATED LID WITH 22 GA LINER
- HOLD OPEN ARM
- HEAVY DUTY HINGE ON 30" DOWNSLOPE SIDE WITH 3/8" PIVOT PINS
- INSULATED 14 GAUGE NON-PITCHED ALUMINIZED STEEL MB CURB
- 12" UPSLOPE CURB HEIGHT
- ALL WELDED CURB CONSTRUCTION CORNERS WELDED
- UPSLOPE FLANGE WITH "UNDER" CONTOURS AND A WATER DIVERTER
- DOWNSLOPE WITH "OVER" CONTOURS

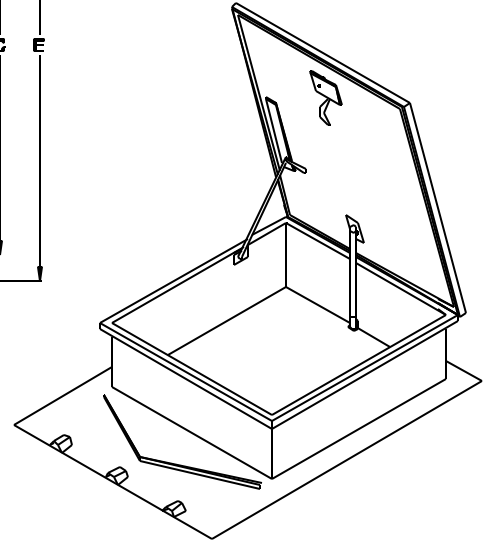
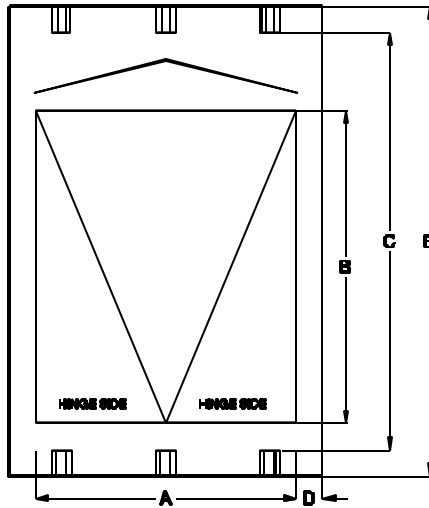

OPTIONS:

- DOMED LID
- SPECIAL HINGE LOCATION
- AIR DRY ENAMEL FINISH (CURB ONLY) -
 - WHITE
 - CUSTOM COLOR
- SPECIAL SIZES
- SPECIAL RIB PLACEMENT
- WIDE FLANGES
 - UPSLOPE
 - SIDE
 - DOWNSLOPE
- CRICKET IN LIEU OF DIVERTER
- SUB FRAMING
- 2-1/2" WIDE MASTIC

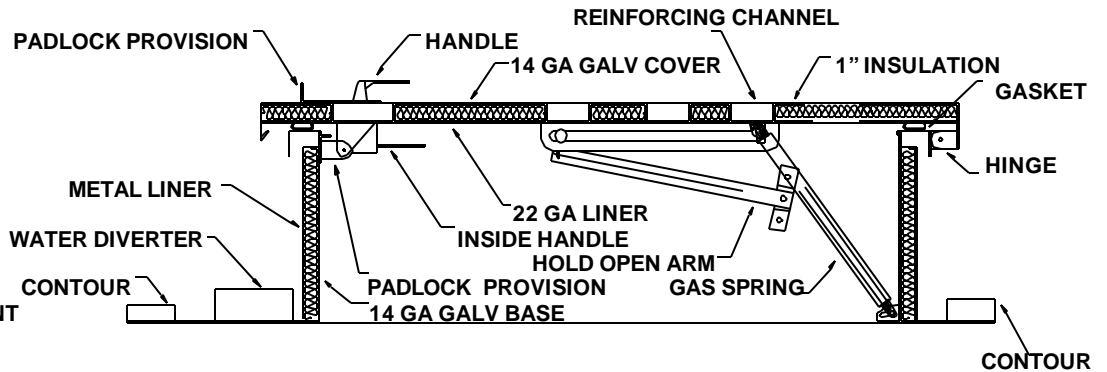

MODEL	INSIDE CURB DIM A	CURB DIM B	DIM C	DIM D	DIM E	QTY
RAH2630MB7	30"	36"	48"	4"	54"	

ROOF PANEL MANUFACTURER	PANEL MODEL

PROJECT _____
 LOCATION _____
 DATE _____

CONTRACTOR _____
 APPROVED BY _____
 DATE APPROVED _____

R & S SALES COMPANY, INC.
 3575 Old Conejo Road, NEWBURY PARK, CA 91320
 PHONE 805-375-3980 FAX 805-375-3981

MODEL RAH-MB7 & RAH-MB8 INSTALLATION DETAILS

1. On a fully sheeted roof, mark centerline of roof opening.
2. Use centerline of major rib as a guide and lay out roof opening to match the curb "A", "C", & "D" dimensions.
3. Cut roof opening per building manufacturer's recommendations. Slit upslope edges of rough opening ("D") for side flange clearance at transition point.
4. Install structural support framing for curb and equipment loads. Keep inside dimension clear. A minimum of two parallel curb walls should be supported. Avoid cantilever sections in excess of 12".
5. Apply mastic or sealant tape at points where curb meets roof panel. Apply to roof panel at curb side, and downslope flanges. Apply to curb upslope flange. Use only accessories as recommended by the building manufacturer.
6. Press curb into place on the roof panel. Upslope flange goes under roof panel; sides and downslope over roof panel.
7. Fasten the curb to support structure through curb flange and roof panel using fasteners compatible with the roof system. Use a minimum of four fasteners per side on maximum 4" centers.
8. Check tightness of fasteners and general integrity of installation. Caulk perimeter edge of curb flanges to roof panel.

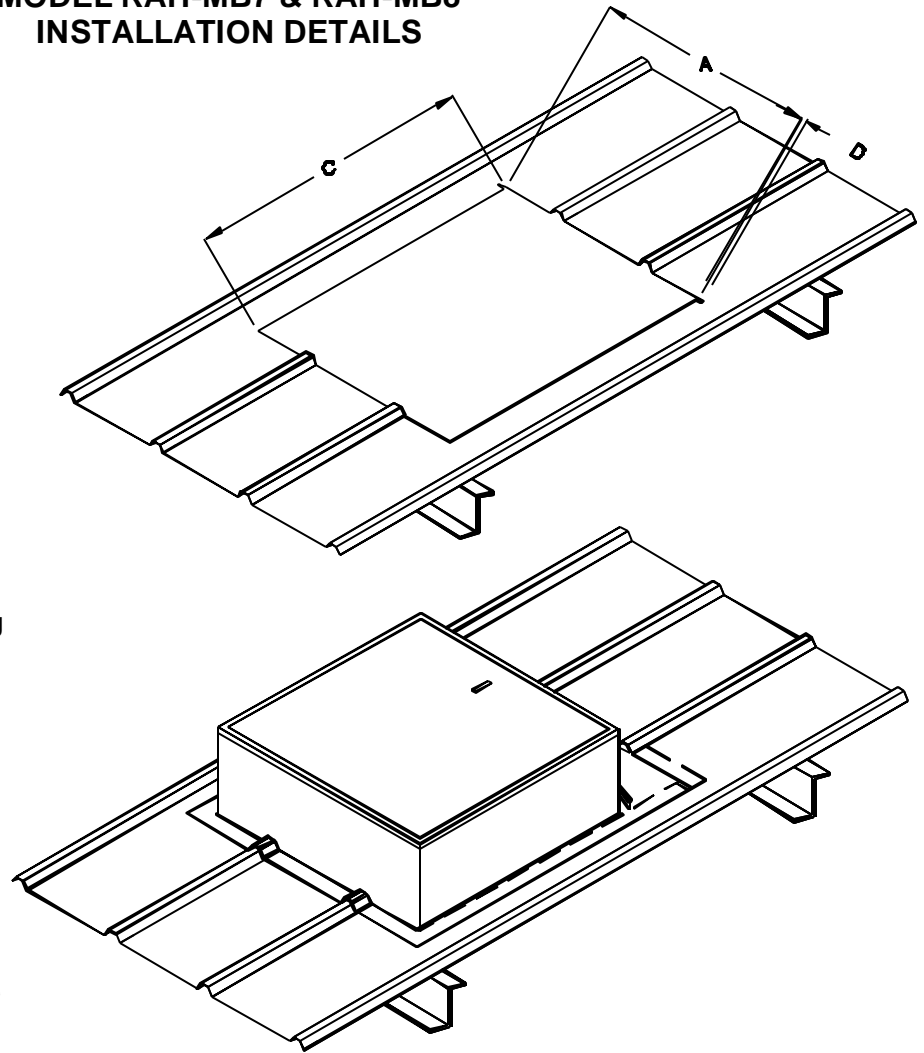

1. ROOF CURB WALL
2. TAPE MASTIC
3. SUPPORT FRAMING
4. COMPATIBLE FASTENER
5. SILICONE/URETHANE SEALANT
6. ROOF PANEL

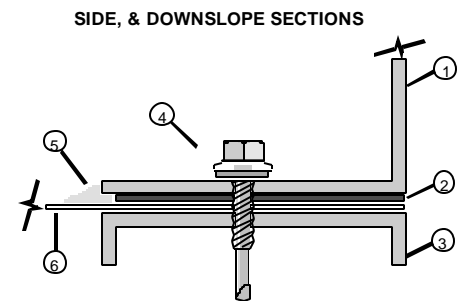

UPSLOPE SECTION

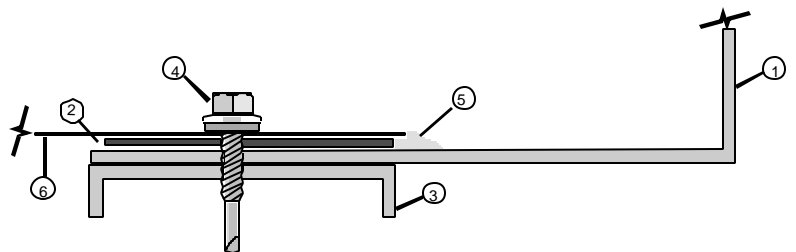

R & S SALES COMPANY, INC.
3575 Old Conejo Road, NEWBURY PARK, CA 91320
PHONE 805-375-3980 FAX 805-375-3981