

# MODEL MB1-RM METAL BUILDING ROOF CURB

**SPECIFICATIONS:**

- 18 GAUGE ALUMINIZED STEEL
- DOUBLE PITCHED TO PROVIDE A LEVEL TOP SURFACE
- 8" MINIMUM CURB HEIGHT
- 1-1/2" WIDE TOP FLANGES
- ALL WELDED CONSTRUCTION  
CORNERS MITERED AND WELDED
- WITH "OVER" CONTOURS
- 1" RIGID R7.2 INSULATION

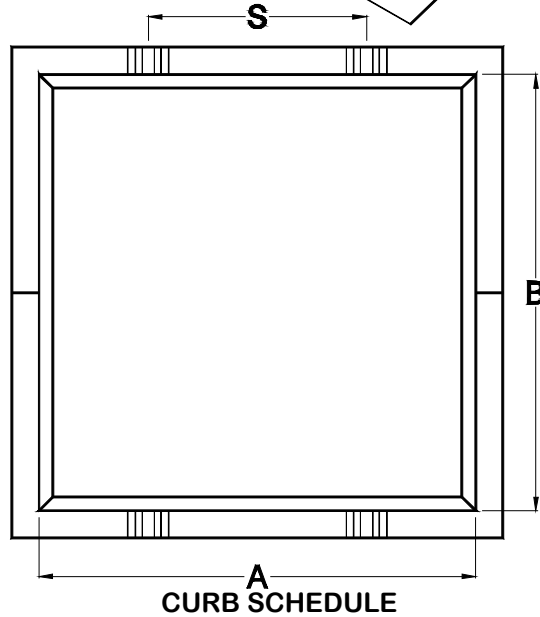
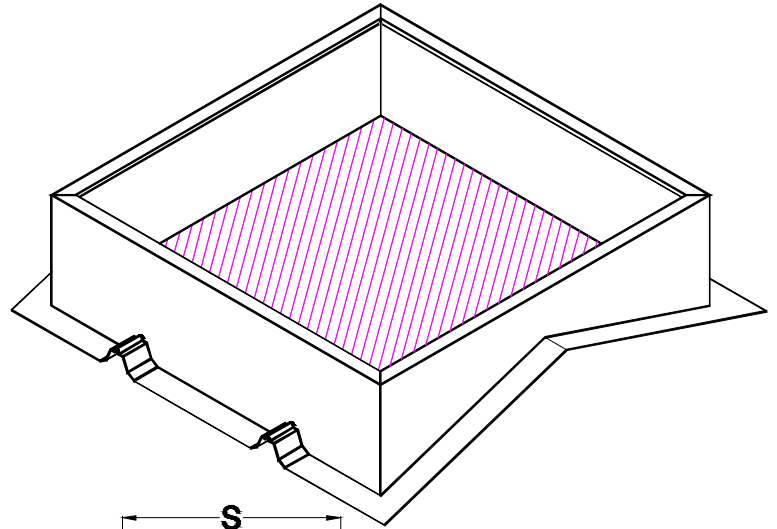

**OPTIONS:**

- 14 GAUGE ALUMINIZED STEEL
- 16 GAUGE ALUMINIZED STEEL
- 0.080" ALUMINUM
- AIR DRY ENAMEL FINISH -
  - WHITE
  - CUSTOM COLOR
- SPECIAL HEIGHT
- DAMPER SHELF/DUCT SUPPORTS
- INSIDE OR OUTSIDE INSULATION LINER
- SPECIAL RIB PLACEMENT
- WIDE FLANGES
  - SIDE
  - DOWNSLOPE
- TOP COVER
- TOP FLANGE BROKEN OUT
- SPLICED CURB (2 PIECES)
- SUB FRAMING
- 2-1/2" WIDE MASTIC

MARK	A	B	S	GA	QTY
ROOF PANEL MFG			PANEL MODEL		PITCH

PROJECT \_\_\_\_\_  
 LOCATION \_\_\_\_\_  
 DATE \_\_\_\_\_

CONTRACTOR \_\_\_\_\_  
 APPROVED BY \_\_\_\_\_  
 DATE APPROVED \_\_\_\_\_

**R & S MANUFACTURING AND SALES COMPANY, INC.**  
 3575 Old Conejo Road, NEWBURY PARK, CA 91320  
 PHONE 805-375-3980 FAX 805-375-3981

## MODEL MB1 & MB2 - RM INSTALLATION DETAILS

1. On a fully sheeted roof, mark centerline of roof opening.
2. Use centerline of major rib as a guide and lay out roof opening to match the curb "A" & "B" dimensions.
3. Cut roof opening per building manufacturer's recommendations.
4. Install structural support framing for curb and equipment loads. Keep inside dimension clear. A minimum of two parallel curb walls should be supported. Avoid cantilever sections in excess of 12".
5. Apply mastic or sealant tape at points where curb meets roof panel. Apply to roof panel at curb side, and downslope flanges. Use only accessories as recommended by the building manufacturer.
6. Press curb into place on the roof panel.
7. Fasten the curb to support structure through curb flange and roof panel using fasteners compatible with the roof system. Use a minimum of four fasteners per side on maximum 4" centers.
8. Check tightness of fasteners and general integrity of installation. Caulk perimeter edge of curb flanges to roof panel.

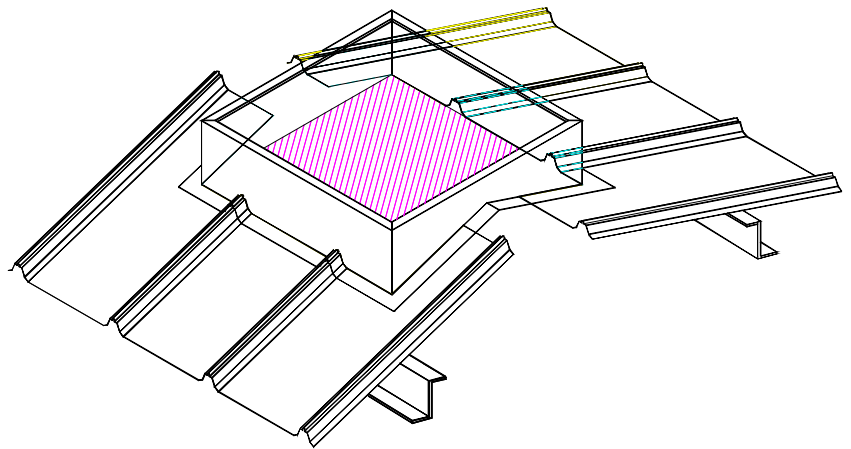
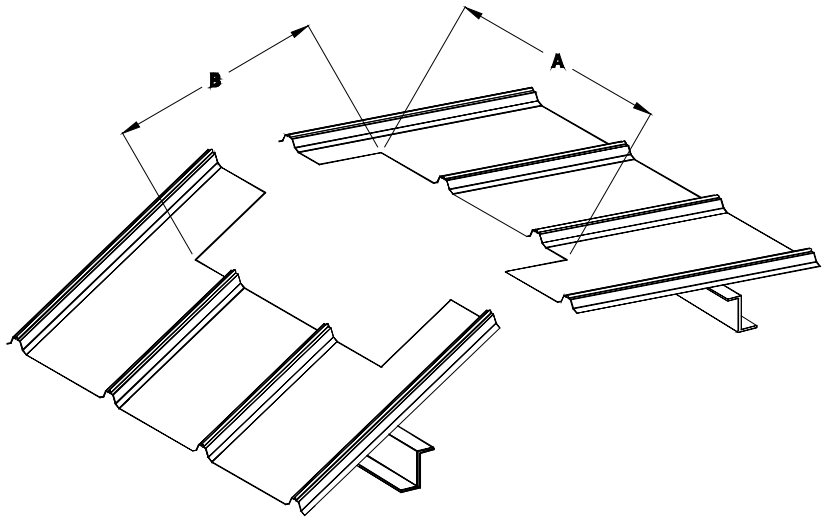

UPSLOPE, SIDE, & DOWNSLOPE SECTIONS

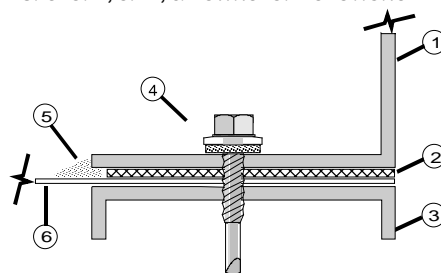

1. ROOF CURB WALL
2. TAPE MASTIC
3. SUPPORT FRAMING
4. COMPATIBLE FASTENER
5. SILICONE/URETHANE SEALANT
6. ROOF PANEL

## R & S MANUFACTURING AND SALES COMPANY, INC.

3575 Old Conejo Road, NEWBURY PARK, CA 91320  
PHONE 805-375-3980 FAX 805-375-3981