

MODEL MB1-IF METAL BUILDING ROOF CURB

SPECIFICATIONS:

- 18 GAUGE ALUMINIZED STEEL
- PITCHED TO PROVIDE A LEVEL TOP SURFACE WHERE SPECIFIED
- 8" MINIMUM CURB HEIGHT
- 1-1/2" WIDE TOP FLANGES
- ALL WELDED CONSTRUCTION
CORNERS MITERED AND WELDED
- UPSLOPE DIVERTER ANGLE & HOOD
- SIDE & REAR CHANNELS, AND DIVERTER PLATE 14 GA SUB-FRAMING
- DOWNSLOPE WITH "OVER" CONTOURS
- 1" RIGID R7.2 INSULATION

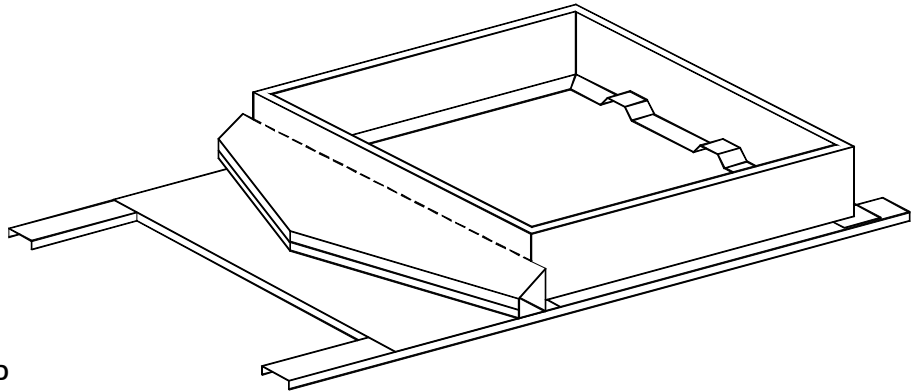

OPTIONS:

- 14 GAUGE ALUMINIZED STEEL
- 16 GAUGE ALUMINIZED STEEL
- 0.080" ALUMINUM
- AIR DRY ENAMEL FINISH -
- WHITE
- CUSTOM COLOR
- SPECIAL HEIGHT
- DAMPER SHELF/DUCT SUPPORTS
- INSIDE INSULATION LINER
- SPECIAL RIB PLACEMENT
- TOP COVER
- TOP FLANGE BROKEN OUT
- INSULATION RETAINERS
- SUB FRAMING
- 2-1/2" WIDE MASTIC
- GUN GRADE POLYURETHANE

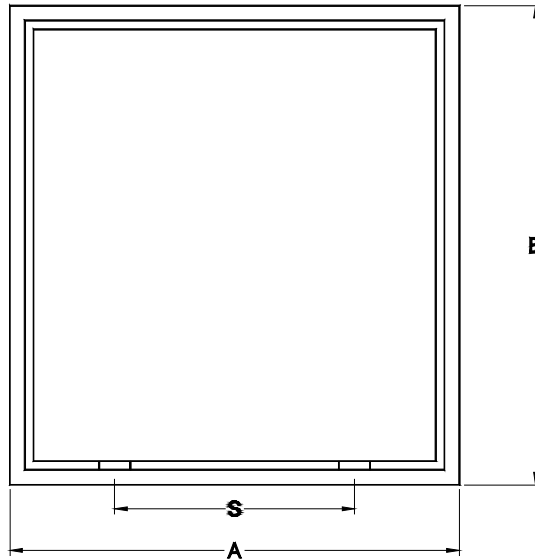

CURB SCHEDULE

MARK	A	B	S	GA	QTY
ROOF PANEL MFG			PANEL MODEL		PITCH

PROJECT _____
 LOCATION _____
 DATE _____

CONTRACTOR _____
 APPROVED BY _____
 DATE APPROVED _____

R & S MANUFACTURING AND SALES COMPANY, INC.
 3575 Old Conejo Road, NEWBURY PARK, CA 91320
 PHONE 805-375-3980 FAX 805-375-3981

MODEL MB1-IF & MB2-IF INSTALLATION DETAILS

1. On a fully sheeted roof, locate & mark centerline of roof opening. Place curb over panels and use inside edge as a template to mark roof opening. Add 11-1/4" to the upslope inner edge and maintain at least 6" from the centerline of the roof panel attachment clips. Cut roof opening per manufacturer's recommended procedure. Install side and rear support channels by positioning them between the roof structure and roof panel. Locate the edge of the roof panel on the diverter plate, and mark 2-1/2" from the upslope edge. Apply tape mastic (minimum 1-1/2") along the line on the diverter plate. Mark the edge of the roof opening on the diverter plate and place mastic on each side with 1/4" exposed to the inside edge. Do not lap mastic. Apply a gun grade polyurethane sealant at each corner. Locate the upslope closure plugs and install with bolts. Apply a gun grade polyurethane sealant over the mastic and closure plugs. Install the diverter plate between the side channels and roof panel.
2. Apply mastic around curb opening with butt joints and a gun grade polyurethane sealant over the mastic. Align the curb edges over the opening and place the curb over the roof opening. Secure the curb to the roof panel using C clamps. Fasten with stainless steel self drilling fasteners 6" on center.
3. Apply tape mastic around the edge of the diverter angle bottom and gun grade polyurethane sealant to the outer edge of the curb front corners and along the junction of the roof panel, curb, and diverter plate. Attach the diverter plate with stainless steel self drilling fasteners and secure the roof panel to the diverter plate 2" on center 3/4" from the panel edge. Install the diverter angle cover. Apply gun grade polyurethane sealant to the downslope contours and curb perimeter as required.

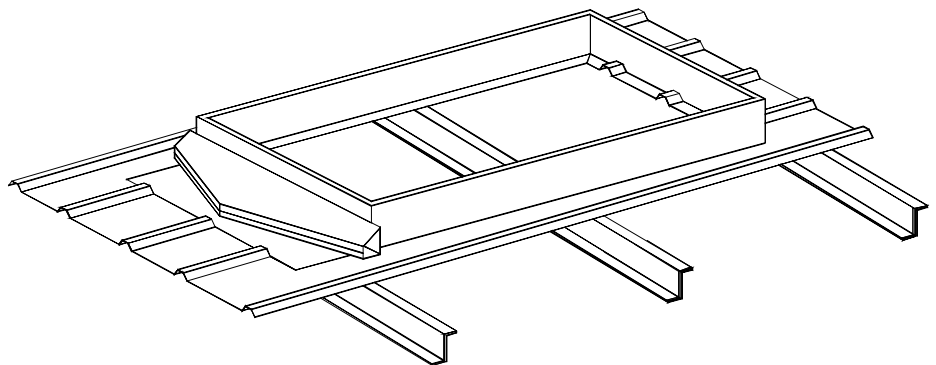
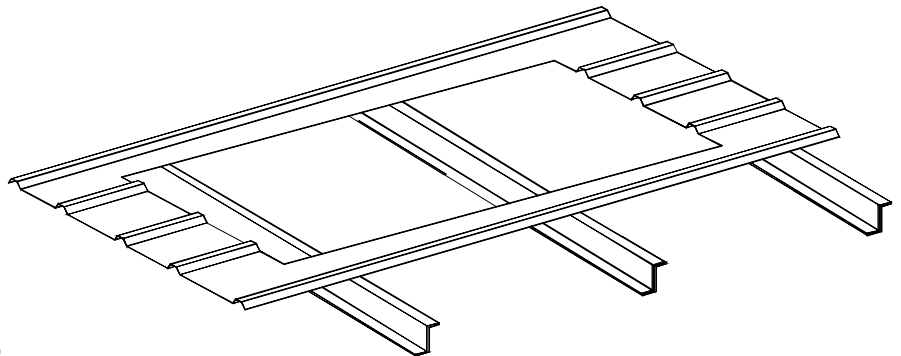
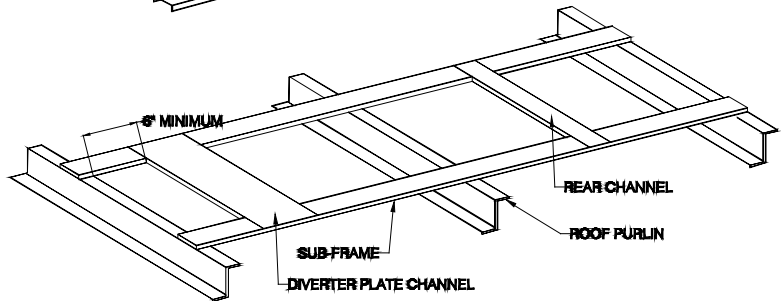
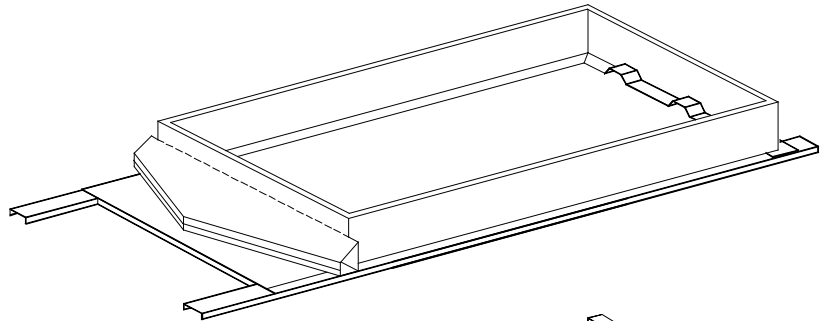

R & S MANUFACTURING AND SALES COMPANY, INC.

3575 Old Conejo Road, NEWBURY PARK, CA 91320
PHONE 805-375-3980 FAX 805-375-3981